



SO TOUGH,
WE GUARANTEE IT.



SSL / SBS Sales Guide

BLOWER-COILS REDUCED-FOOTPRINT, VERTICAL

/// SSL

/// SBS



SSL / SBS Series: BIG ON FEATURES; SMALL IN SIZE



Contractors

All SSL/SBS model blower-coil units are shipped completely assembled, reducing field-installation time and labor. All units are thoroughly inspected and tested prior to shipment, eliminating potential problems at startup. Motor wiring is brought to a junction box and terminated. The junction box is located on the outside of the unit casing, reducing electrical hook-up time.

A wide variety of fan-discharge configurations allow for increased flexibility and easier installation on the jobsite, resulting in cost reductions by eliminating expensive elbows, etc.

Designers

The extensive variety of standard options available on the SSL/SBS units are where you find the versatility to fit any HVAC system designer's needs.

Options include: Mixing boxes with standard low-leak dampers, blow-thru electric heat with single-point power connection. All electric heat units are listed with ETL as an assembly and carry the cETL label.

High-efficiency motors, starters, disconnects and fusing mean easier coordination between mechanical and electrical trades. Coil options allow for 4 or 6-row cooling coils.

Owners

SSL/SBS model blower coils are constructed from galvanized steel, surpassing the ASTM 125-hour, salt-spray test for corrosion and rust. Insulation, which is 1-inch thick, scrimreinforced, and foil-faced, is glued, pinned and taped for maximum adhesion. Insulation complies with UL 181, ASTM-C1071, NFPA 90A and 90B and meets bacteriological standard ASTM-C665 and C1136 for mold, mildew and humidity resistance.

All units, with or without electric heat, are cETL-listed and labeled. All wiring is in compliance with NEC, assuring safety and quality for the owner.



Typical Installations

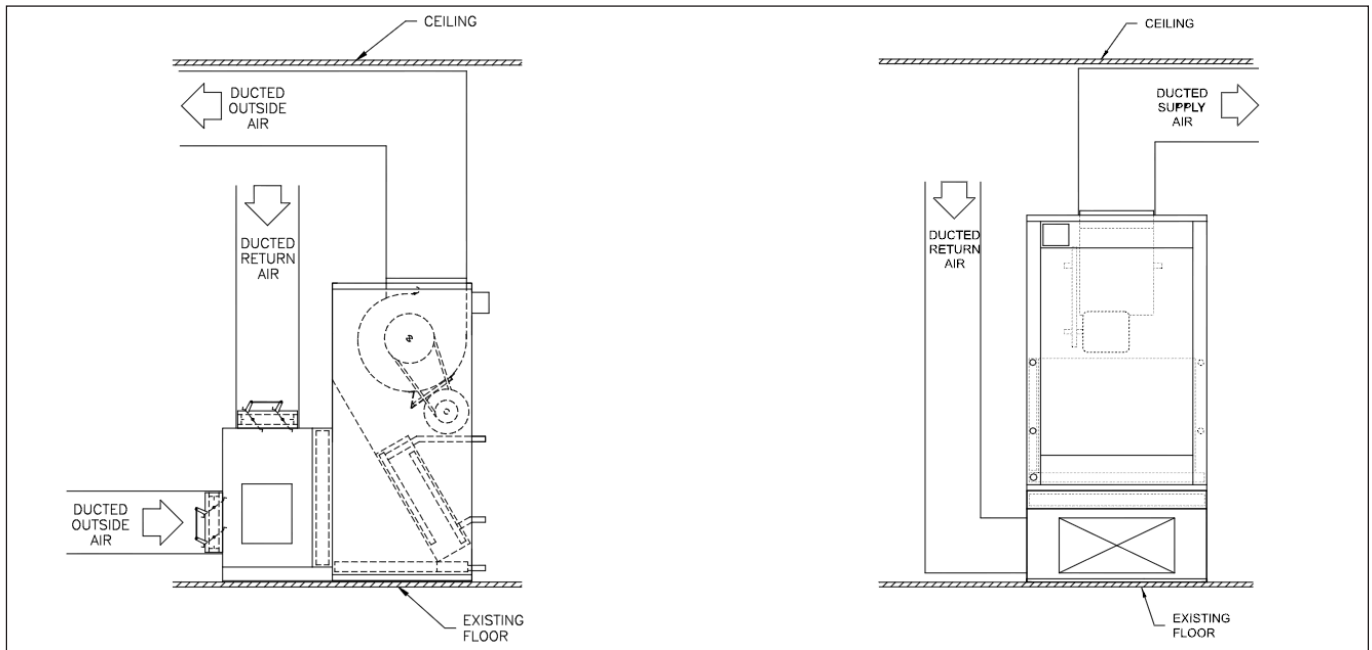

Model SBS, Rear Return with Mixing Box
Mechanical Room Layout

Model SSL, Bottom Return with Return Plenum
Closet or Confined Space Layout

SSL / SBS Series: DIMENSIONS, COIL & FILTER DATA

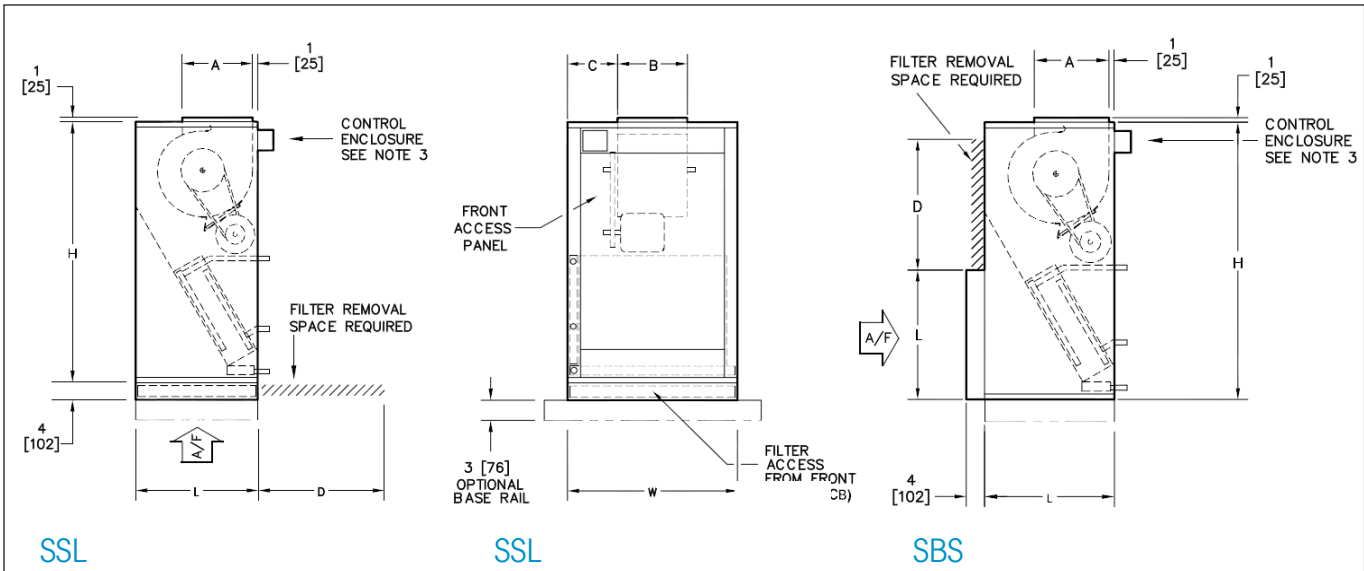

Unit Size	H	W	L	A	B	C	D
08	46 [1168]	26 [660]	19 [483]	6½ [165]	6⅞ [175]	9⅞ [243]	16 [406]
12	46 [1168]	26 [660]	21 [533]	7½ [190]	8¼ [210]	8⅞ [225]	20 [508]
16	54 [1372]	29 [737]	25 [635]	7½ [190]	10¼ [260]	9⅞ [238]	24 [610]
20	54 [1372]	29 [737]	28 [711]	11⅞ [289]	13¼ [337]	7⅞ [200]	24 [610]
25	60 [1524]	39 [991]	28 [711]	13½ [343]	12⅞ [327]	13⅞ [332]	24 [610]
30	60 [1524]	39 [991]	28 [711]	15¼ [387]	15 [381]	12 [305]	24 [610]

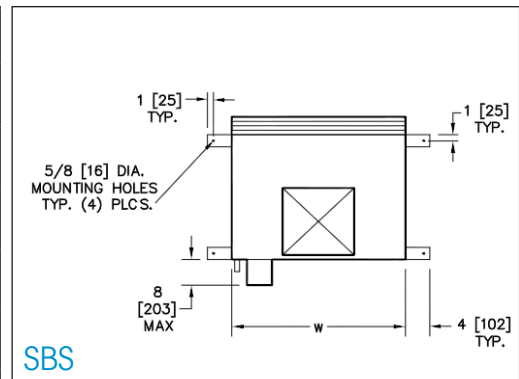

Coil Face Area and Filter Data

Unit Size	Nominal CFM	Internal Cooling and Heating Coils	Discharge Section Heating Coils	2" Filters (Quantity) and Size	Filter Face Area
08	800	2.1 [0.20]	2.1 [0.20]	(1) 16" x 20" x 2" [406 x 508 x 51]	2.2 [0.20]
12	1200	2.8 [0.26]	2.1 [0.20]	(1) 20" x 20" x 2" [508 x 508 x 51]	2.8 [0.26]
16	1600	3.6 [0.33]	3.2 [0.30]	(1) 24" x 24" x 2" [610 x 610 x 51]	4.0 [0.37]
20	2000	4.8 [0.45]	3.2 [0.30]	(1) 24" x 24" x 2" [610 x 610 x 51]	4.0 [0.37]
25	2500	5.7 [0.53]	4.6 [0.43]	(1) 24" x 24" x 2" [610 x 610 x 51] (1) 12" x 24" x 2" [305 x 610 x 51]	6.0 [0.56]
30	3000	6.8 [0.63]	5.7 [0.53]	(1) 24" x 24" x 2" [610 x 610 x 51] (1) 12" x 24" x 2" [305 x 610 x 51]	6.0 [0.56]

Notes:

- Standard filters are 2" throwaway; optional filters are 2" pleated
- Filter sizes are nominal and standard size, measured in inches [mm]
- Coil and filter face areas are measured in square feet [square meters]

Notes:

- All dimensions are inches [mm] and are +/- 1/8" [6mm]
Metric values are soft conversions
- Motor/drive location may be specified Left or Right Hand. Standard control-enclosure location matches motor/drive position.
- Provide sufficient clearance to access electrical controls and comply with all applicable codes and ordinances
- Maximum total internal coil rows: 6
- Left-hand unit shown; right-hand unit has CW and HW piping connections mirrored
- Filter assembly runs the full length of the unit size
- Drawings not for installation purposes

Note: Drawings are not to scale and are not for installation purposes. Contact your Superior Rex representative for more information. All data and dimensions are subject to change without notice.

SSL / SBS Series: BLOWER-COIL UNIT FEATURES

Standard Features:

Construction

- » Galvanized-steel cabinet construction, minimum 18 gauge
- » 1"-thick, 1.6-lb/ft, 3 scrim-reinforced, foil-faced insulation, glued, taped and pinned in place
- » 1" supply duct collars
- » Gasketed, removable access panel sized for easy handling
- » Galvanized-steel drain pan with 1-1/8" ODM copper pipe outlet
- » Left- and right-hand arrangement

Fan Assembly

- » Forward-curved (double-width, double-inlet) fans
- » Statically and dynamically balanced
- » Solid steel shafting
- » Ball bearings with a minimum design-average life (L_{50}) of 100,000 hours

Fan Motor and Drive

- » NEMA-design ODP motors
- » 1750 RPM, single-speed, 60 Hertz
- » Single-phase motors with inherent thermal protection
- » Three-phase motors
- » Rigid-mount, adjustable, motor base
- » Standard cross-section "V-belt" drive with 1.2 service factor
- » Adjustable-pitch motor pulley and fixed-pitch blower pulley

Coils

- » AHRI Standard 410-certified and labeled
- » 1/2" O.D. seamless copper tubes
- » Collared and corrugated aluminum fins
- » Manual air-vent plug on all water coils
- » 300 PSIG working pressure at 200°F
- » Steam coils rated at 15 PSIG maximum
- » Copper ODM sweat connections
- » 0.016" tube wall on water and evaporator coils
- » 0.025" tube wall on steam coils
- » High-efficiency, aluminum-fin surface for optimizing heat transfer, pressure drop, and carryover

Filters and Filter Rack

- » Top-access, flat-filter rack (SBS only)
- » Front-access filter rack (SSL only)
- » Standard-size, 2" nominal, throwaway filters

Electrical

- » Fan motor wired and terminated to J-box
- » All units ETL-listed in compliance with UL/ANSI

Optional Features:

Construction

- » Stainless-steel drain pan with 1" MPT galvanized pipe outlet
- » External rubber-in-shear or spring-type vibration isolators, floor mount
- » Fan-discharge arrangements
- » Discharge plenum w/dbl.-deflection discharge grille
- » Access panel with lift-and-turn fasteners
- » Double wall access panel w/lift-and-turn fasteners
- » Return plenum with removable panels (SSL only)
- » Base rails with rigging slots, factory-assembled and installed

Fan Motor and Drive

- » TEFC motors
- » High-efficiency motors

Coils

- » 4 and 6-row chilled-water or DX coils
- » 1 and 2-row hot-water coils
- » 1 and 2-row hot-water or standard-steam coils in discharge-coil section only
- » Hot-water coil in preheat or reheat position
- » Stainless-steel coil casings
- » 0.025" tube wall on water and evaporator coils
- » Auto air vents on water coils

Filters and Filter Rack

- » Side-access filter rack (SBS only)
- » 2" pleated filter (MERV 8)
- » Spare throwaway or pleated filters

Inlet-Damper Section (SBS rear-return unit)

- » Factory-assembled and installed
- » Heavy-gauge, galvanized-steel, formed blade dampers
- » Low-leak dampers with extruded-vinyl blade seals and flexible-metal jamb seals
- » Parallel-blade operation
- » Interconnecting damper linkage

Electrical

- » Motor wiring in conduit
- » Motor starter (contactor with overload for three-phase; contactor for single-phase), factory-installed (mounted and wired)
- » Door-interlocking disconnect switch (non-fused) (with main fusing)
- » Hand-off-auto switch (HOA)
- » Main fusing

Notes

Electric-Heat Section

- » Factory-mounted electric heater with single-point power connection, ETL-listed as an assembly

Notes

Notes



Superior Rex
605 Shiloh Road
Plano Texas 75074
(ofc): 972.212.4800
(fax): 972.212.4884

SO TOUGH, WE GUARANTEE IT! | www.superiorrex.com